



**CBT3518FW | 177 cm**



Wi-Fi



CLASSE  
ENERGETICA



TOTAL  
NO FROST



TOTAL NO FROST  
CIRCLE+



SKY LED



PORTE  
REVERSIBILI

## FRIGORIFERO COMBINATO TOTAL NO FROST

- Connettività Wi-Fi con App hOn
- Classe Energetica F
- Classe climatica ST
- Controllo elettronico indipendente Frigo/Freezer
- Tecnologia Total No Frost
- Tecnologia Candy Circle+
- Volume totale netto Frigorifero 187 litri
- Volume totale netto Congelatore 61 litri
- 4 ripiani in vetro trasparente
- 2 + 3 balconcini controporta trasparenti
- 1 cassetto crisper
- Portabottiglie in metallo
- Illuminazione SKY LED
- Freezer a 3 scomparti con cassette trasparenti
- Sistema antibatterico
- Porta reversibile

# COMBINATO

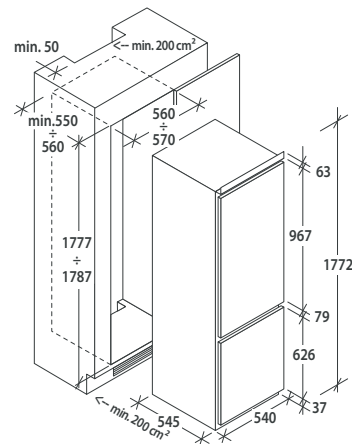

34901397 CBT3518FW